



General Certificate of Secondary Education  
2022

Centre Number

--	--	--	--	--

Candidate Number

--	--	--	--	--

# Physics

Unit 3 Practical Skills

**Booklet B**

Higher Tier

**[GPY34]**

\*GPY34\*

**TUESDAY 28 JUNE, MORNING**

## TIME

1 hour 15 minutes.

## INSTRUCTIONS TO CANDIDATES

Write your Centre Number and Candidate Number in the spaces provided at the top of this page.

**You must answer the questions in the spaces provided.**

**Do not write outside the boxed area on each page or on blank pages.**

Complete in black ink only. **Do not write with a gel pen.**

Answer **all** questions.

## INFORMATION FOR CANDIDATES

The total mark for this paper is 70.

Figures in brackets printed down the right-hand side of pages indicate the marks awarded to each question or part question.

Quality of written communication will be assessed in Question **1(b)**.

You should have a ruler and a protractor.



- 1 (a) A student uses multiflash photography to measure the acceleration of free fall. A ball is released from rest close to a vertically mounted metre rule.

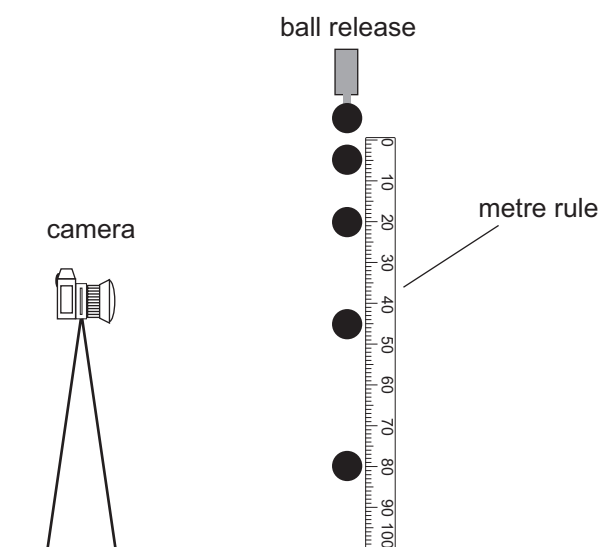

Source: Principal Examiner

At the moment of release a multiflash camera starts to take photographs every 0.05 s.

The experiment is carried out twice (Trial 1 and Trial 2).

The distance fallen by the ball each time is recorded in the table.

Time/s	Distance fallen /cm Trial 1	Distance fallen /cm Trial 2	Average distance fallen/cm
0.0	0.0	0.0	0.0
0.05	1.2	1.4	1.3
0.10	5.0	5.0	5.0
0.15	12.0	10.0	11.0
0.20	18.0	22.0	20.0
0.25	31.0	29.0	
0.30	43.0	45.0	
0.35	58.0	60.0	
0.40	82.0	78.0	
0.45	100.0	100.0	



(i) Complete the last column of the table, writing the average distance fallen to one decimal place. [2]

(ii) Suggest how you can tell from inspection of the table, and without doing any calculations, that the ball was moving faster as it fell.

\_\_\_\_\_ [1]  
\_\_\_\_\_

(iii) Write **in words**, in the box below, the equation you would use to calculate the average speed of the ball.

Average speed =

[1]

(iv) Use your answer to (iii) and the values in the table to show that the average speed of the ball **in m/s** between times  $t = 0$  and  $t = 0.45$  s is **2.22 m/s**. Show your calculation below.

[3]

[Turn over



- (v) Using the equation below calculate the **final speed** of the ball at time **t = 0.45 s**.  
Give your answer to **2 decimal places**.  
Remember the ball drops from rest.

$$\text{Average speed} = \frac{(\text{initial speed} + \text{final speed})}{2}$$

Final speed = \_\_\_\_\_ m/s [2]

- (vi) Given that the speed of the ball at 0.2 s was 2.00 m/s, calculate the acceleration of the ball between 0.2 s and 0.45 s.  
**Show clearly how you get your answer, starting with the equation you plan to use.**

Acceleration = \_\_\_\_\_ m/s<sup>2</sup> [4]



(vii) All GCSE Physics students learn that all objects close to the surface of the Earth fall with a constant acceleration of  $10 \text{ m/s}^2$ . Explain what is meant by an acceleration of  $10 \text{ m/s}^2$ .

\_\_\_\_\_

\_\_\_\_\_ [2]

[Turn over

12982



\*20GPY3405\*

(b) A hypothesis has been suggested that:

**the average speed of a marble rolling down a ramp is directly proportional to the height of the ramp.**

A diagram of the ramp set up for the investigation of this hypothesis is shown below.

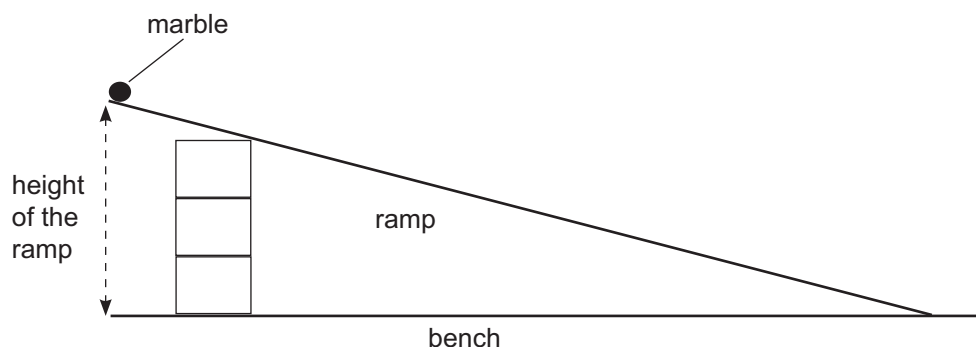

Source: Principal Examiner

**In this question you will be assessed on your written communication skills including the use of specialist science terms.**

Describe the planning you would carry out for this investigation.  
Write your answers on the page opposite.

In your plan you must:

- state the dependent and independent variables;
- state one controlled variable;
- identify **two** additional pieces of laboratory apparatus you would need to carry out the investigation;
- state the graph you would plot to test if the hypothesis was true or false;
- state the appearance of the graph if the hypothesis was true.



Dependent variable: \_\_\_\_\_

\_\_\_\_\_

Independent variable: \_\_\_\_\_

\_\_\_\_\_

Controlled variable: \_\_\_\_\_

\_\_\_\_\_

Two additional pieces of laboratory apparatus: \_\_\_\_\_

\_\_\_\_\_

Graph to be plotted: \_\_\_\_\_

\_\_\_\_\_

Appearance of graph if hypothesis is true: \_\_\_\_\_

\_\_\_\_\_

\_\_\_\_\_ [6]

[Turn over



- 2 (a) (i) In the space below, complete the circuit diagram that is needed to obtain a number of voltage and current values for a filament bulb. You must use the **correct symbols** for the components.

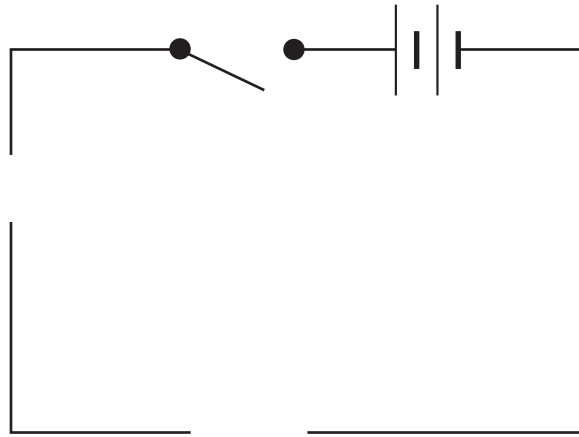

Source: Chief Examiner

[5]

- (ii) Describe how you would obtain a number of readings of voltage and current.

---

---

[1]



- (iii) The table below shows a number of readings of voltage and current for the bulb.  
 On the grid below, plot a  $V - I$  graph, voltage on the y-axis and current on the x-axis.  
 Clearly mark your data points using  $\odot$  or  $\otimes$ .  
 Label each axis with the quantity and unit.  
 Draw a smooth curve through the points.

Voltage/V	Current/mA
0	0
1	25
2	35
3	40
4	45
5	50

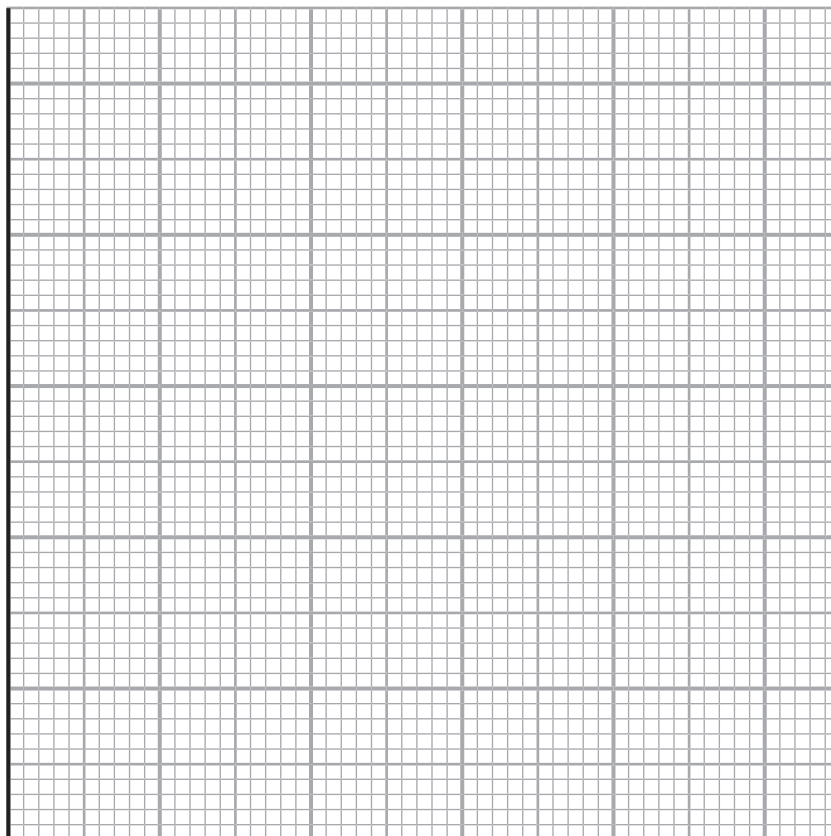

[5]

[Turn over



(iv) Is the current proportional to the voltage? Answer yes or no. \_\_\_\_\_  
Explain your answer.

---

---

---

[2]

(b) (i) Using data from the table calculate the resistance of the bulb for a current of 50 mA. Record your answer in the table below.  
Remember the current is measured in mA.  
**Add the unit for resistance to the table.**

Voltage/V	Current/mA	Resistance/_____
1	25	40
2	35	57
3	40	75
4	45	89
5	50	

[5]

Use the space below for your calculation.



(ii) The resistance of the bulb is **not** proportional to the current.  
Show that this is true by carrying out at least **two** calculations.  
Use the space below for your calculations.

[2]

[Turn over

12982



\*20GPY3411\*

- 3 (a) An experiment has been carried out to measure the power output of an electric motor. The motor was used to lift a mass. The experiment was repeated to obtain a number of values for the time taken. The apparatus used and the results obtained are shown below.

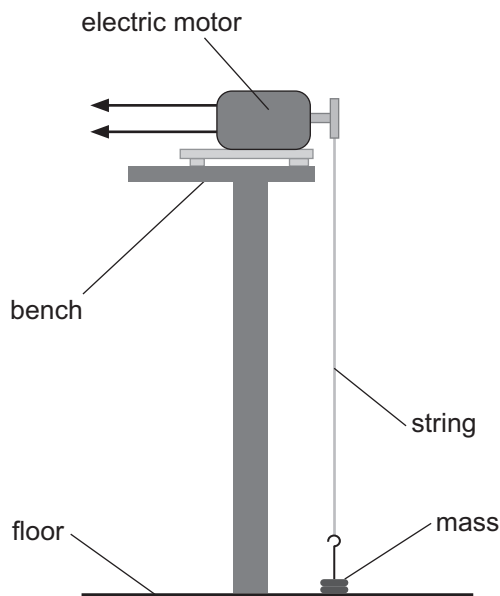

Source: Chief Examiner

Mass lifted/kg	0.2
Height lifted/m	1.2
Time taken/s	0.82 0.81 0.95 0.83

Calculate the weight of the mass.  
**Show clearly how you get your answer.**

Weight = \_\_\_\_\_ N [1]



- (b) (i) One of the time values in the table is clearly an anomalous result. State which one is anomalous and give reason for your answer.

Anomalous result = \_\_\_\_\_

Reason \_\_\_\_\_

\_\_\_\_\_ [2]

- (ii) If an anomalous result is noticed **during** the experiment, what should the person carrying out the experiment do?

\_\_\_\_\_ [1]

- (iii) Using an average value for the time taken, and with the help of the equation below, calculate the **average** output power of the motor.

$$\text{work done} = \text{load lifted} \times \text{height lifted}$$

Show clearly how you get your answer.

\_\_\_\_\_ W [4]

[Turn over



- (c) In another experiment, the motor was used to lift different masses. The efficiency of the electric motor was measured for each mass. The results are shown in the graph below.

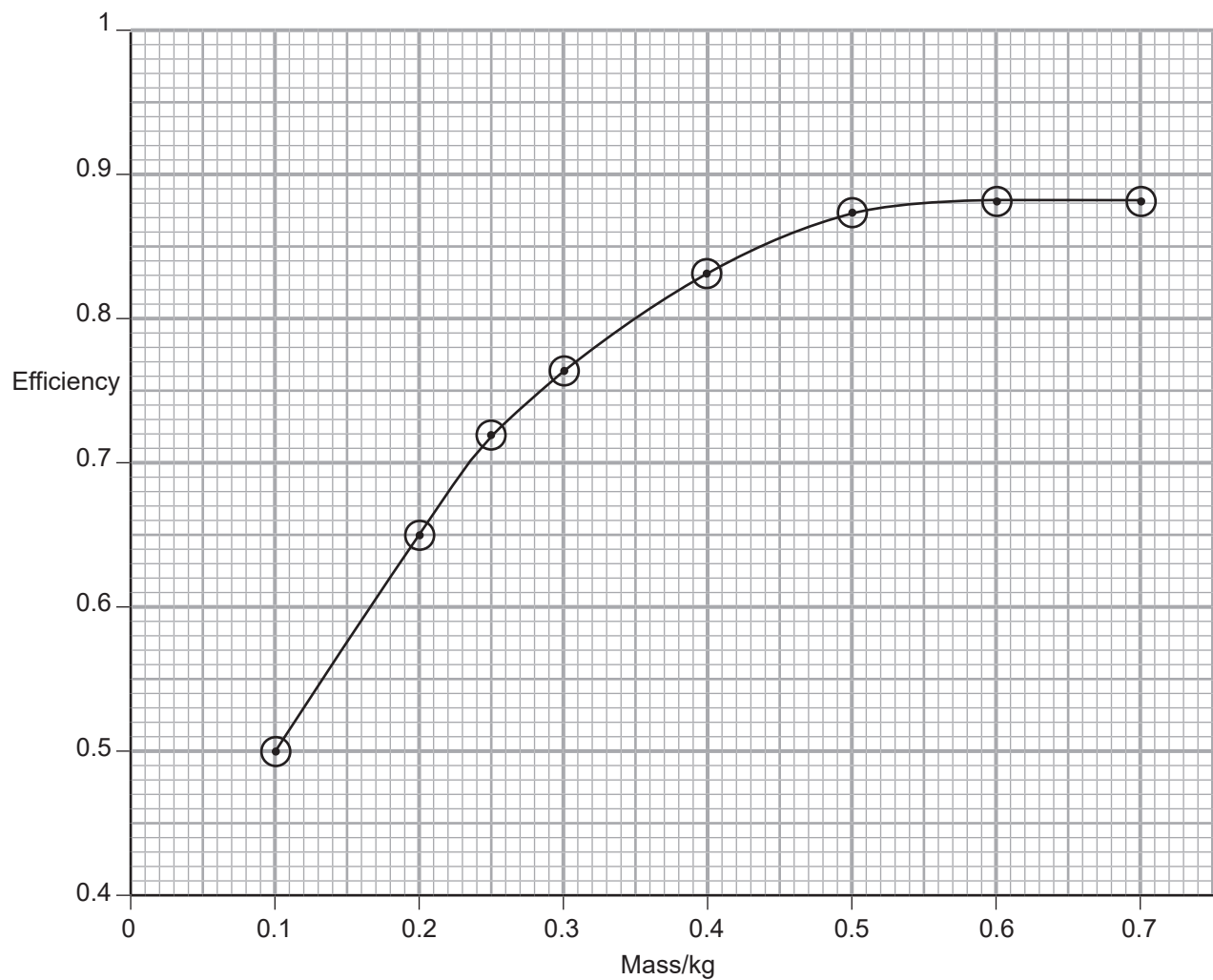

- (i) Use the graph to determine the efficiency of the motor when lifting a mass of 0.2 kg.

\_\_\_\_\_ [1]



- (ii) Using the answer to (c)(i) and your answer to (b)(iii), calculate the **input power** to the motor when the mass being lifted was 200 g. Make use of the equation which is shown below.

$$\text{Efficiency} = \frac{\text{Useful output power}}{\text{Total input power}}$$

Show clearly how you get your answer.

Input power = \_\_\_\_\_ W [2]

- (iii) Explain, in terms of energy, why the efficiency of this motor will always be less than 1 (100%).

\_\_\_\_\_  
\_\_\_\_\_ [1]

- (d) Risk assessments describe how to reduce the risk of harm when carrying out the experiment on page 12. Name one step that could be taken to reduce harm to anyone using the apparatus shown to measure the power of an electric motor.

\_\_\_\_\_  
\_\_\_\_\_ [1]

[Turn over



- 4 The diagram below shows the path of a light ray as it enters, passes through and leaves a glass block.

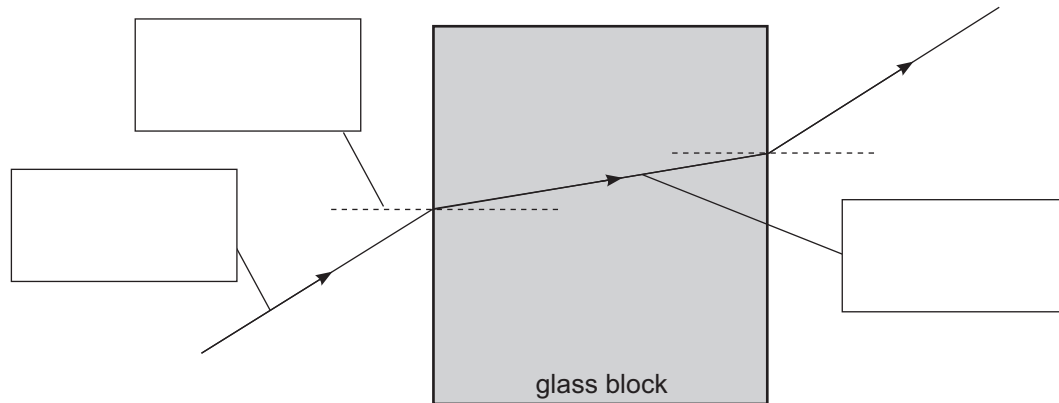

Source: Principal Examiner

- (i) Complete the diagram by adding names to the rays and the dotted lines. Write your answers in the boxes provided. [3]
- (ii) Mark clearly with an *i* the angle of incidence as the light enters the block. [1]
- (iii) Mark clearly with an *r* the angle of refraction as the light enters the block. [1]
- (iv) Explain why the light changes direction as it enters the glass block.

---

---

[2]



(b) A student recorded the corresponding angles of incidence and refraction for the light ray upon entering the glass block.

The results are shown in the table below.

Angle of incidence $i / ^\circ$	Angle of refraction $r / ^\circ$	$\frac{i}{r}$
5	3	
10	7	
20	13	
30	19	
50	31	
65	37	
80	41	

(i) Complete the table by calculating, to **one decimal place**, the ratio  $\frac{i}{r}$  for each pair of angles.

[2]

(ii) The angle of refraction increases as the angle of incidence increases. However they are not proportional. Explain how the values calculated in the table support this.

---

---

---

[1]

[Turn over



- (iii) On the grid below plot a graph of angle of refraction (y-axis) against the angle of incidence (x-axis).  
Label each axis.  
Choose a suitable scale for each axis.  
Plot the points using  $\odot$  or  $\times$ .  
Draw the best fit line through the points.

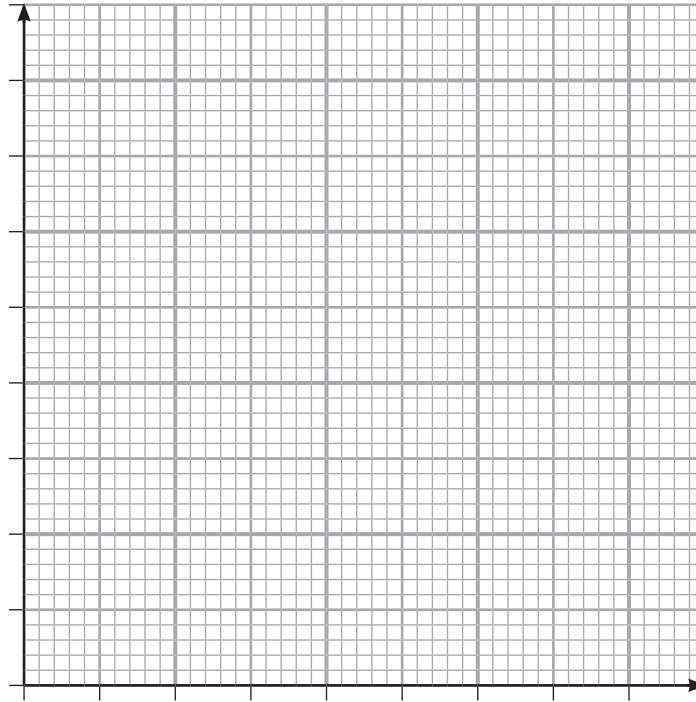

[5]

- (iv) Explain what feature of the graph confirms that the angles of refraction and incidence are not proportional.

---

---

[1]

---

**THIS IS THE END OF THE QUESTION PAPER**

---





**BLANK PAGE**

**DO NOT WRITE ON THIS PAGE**

12982



\*20GPY3419\*

**DO NOT WRITE ON THIS PAGE**

For Examiner's use only	
Question Number	Marks
1	
2	
3	
4	
<b>Total Marks</b>	

Examiner Number

Permission to reproduce all copyright material has been applied for.  
In some cases, efforts to contact copyright holders may have been unsuccessful and CCEA will be happy to rectify any omissions of acknowledgement in future if notified.

GPY34/8  
260989



\*20GPY3420\*